

Routing Optimization in NEMO

Thierry Ernst

WIDE / Keio University ernst@sfc.wide.ad.jp

<http://www.sfc.wide.ad.jp/~ernst/>

<http://www.nautilus6.org>



- ◆ NEMO WG's NEMO Basic Support specification
- ◆ NEMO WG Status on RO
- ◆ Mobility Problem
- ◆ Potential RO Approaches
- ◆ RO a la MIP6

IETF NEMO Basic Support: draft-ietf-nemo-basic-support

- ◆ Assumption:
 - ◆ All MNNs have an address on NEMO-Prefix
 - ◆ CoA bound to NEMO-Prefix
- ◆ Registration
 - ◆ Registration with HA:
 - ◆ **NEMO-prefix-> MR' CoA**
 - ◆ instead of
 - ◆ **MR's HoA-> MR's CoA**
 - ◆ HA records a network-specific route instead of host-specific
 - ◆ Bidirectional tunnel between MR and HA

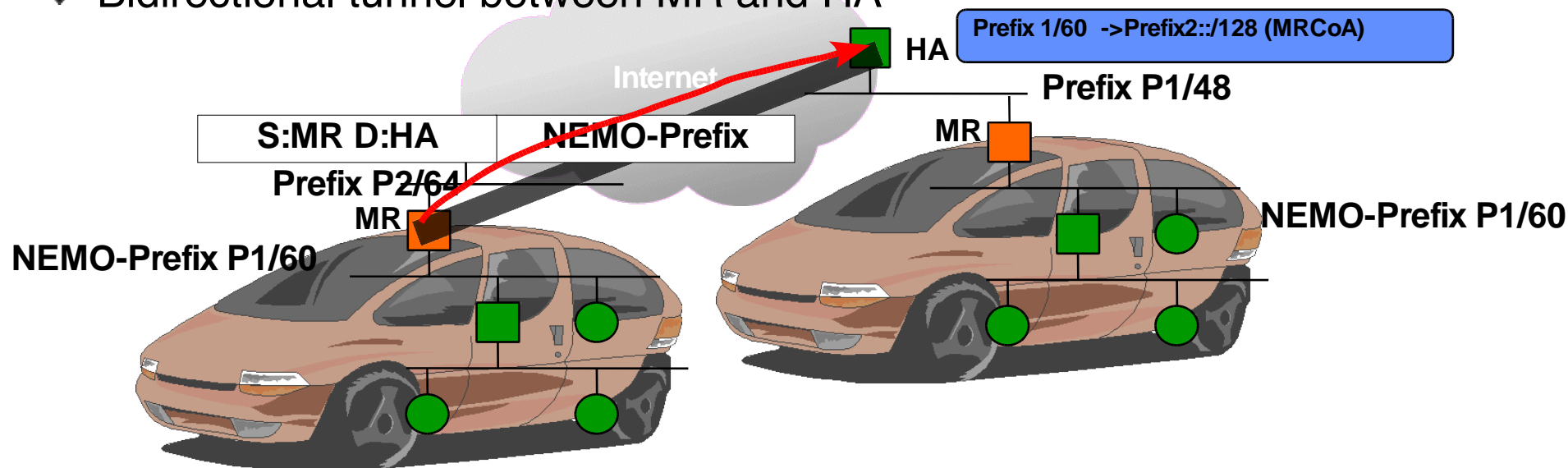

IETF NEMO Basic Support: draft-ietf-nemo-basic-support

- ◆ Routing
 - ◆ Encapsulation between HA and MR in BOTH directions
 - ◆ Not optimal solution, but guarantee mobile networks are supported with minimal effort

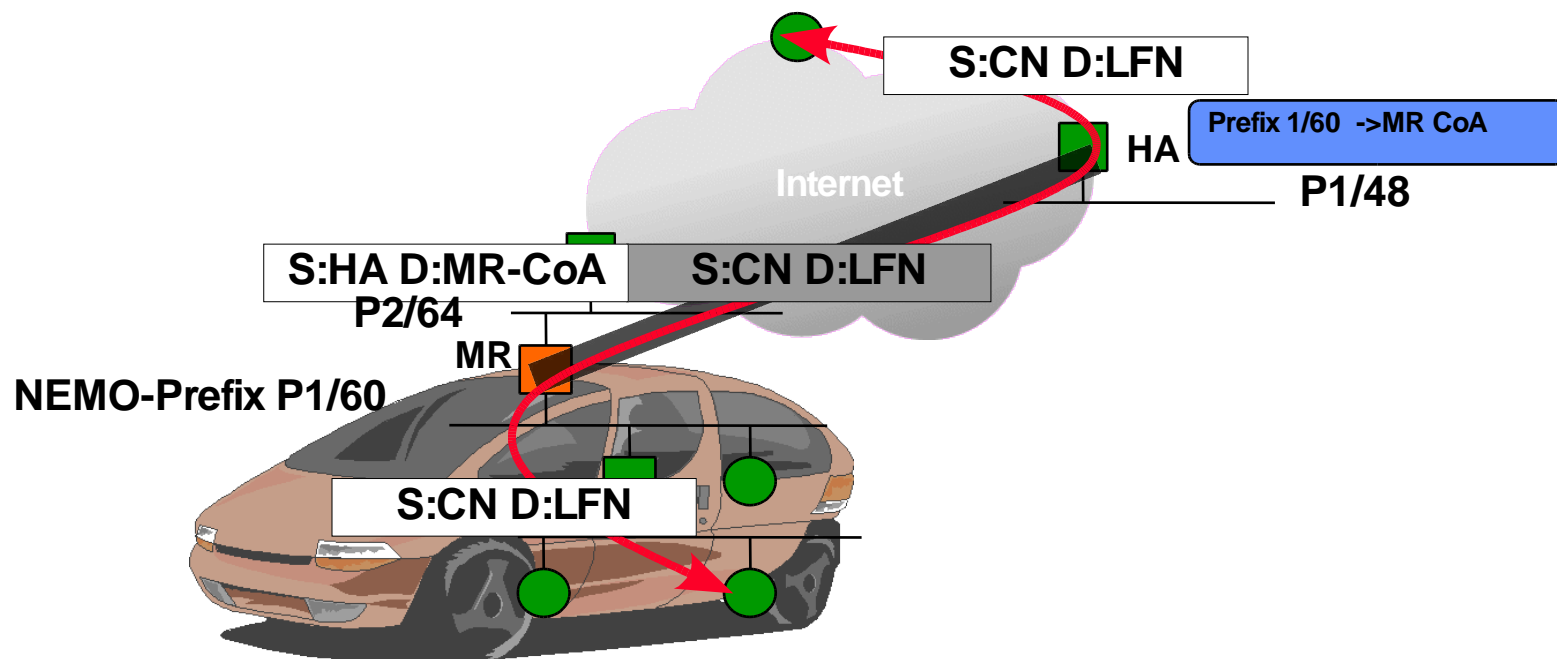

NEMO Basic Support Issue: Nested Mobility

- ◆ Cost of multiple encapsulation
 - ◆ Packet size ;
 - ◆ Packet Fragmentation (PMTU)
 - ◆ Latency
 - ◆ Processing overhead at MR, HA
 - ◆ Extremely sub-optimal routing (Pin Ball routing)
- ◆ Sol investigated in:
 - ◆ draft-ng-nemo-access-router-option-00.txt
 - ◆ draft-thubert-nemo-reverse-routing-header-05.txt
 - ◆ Others

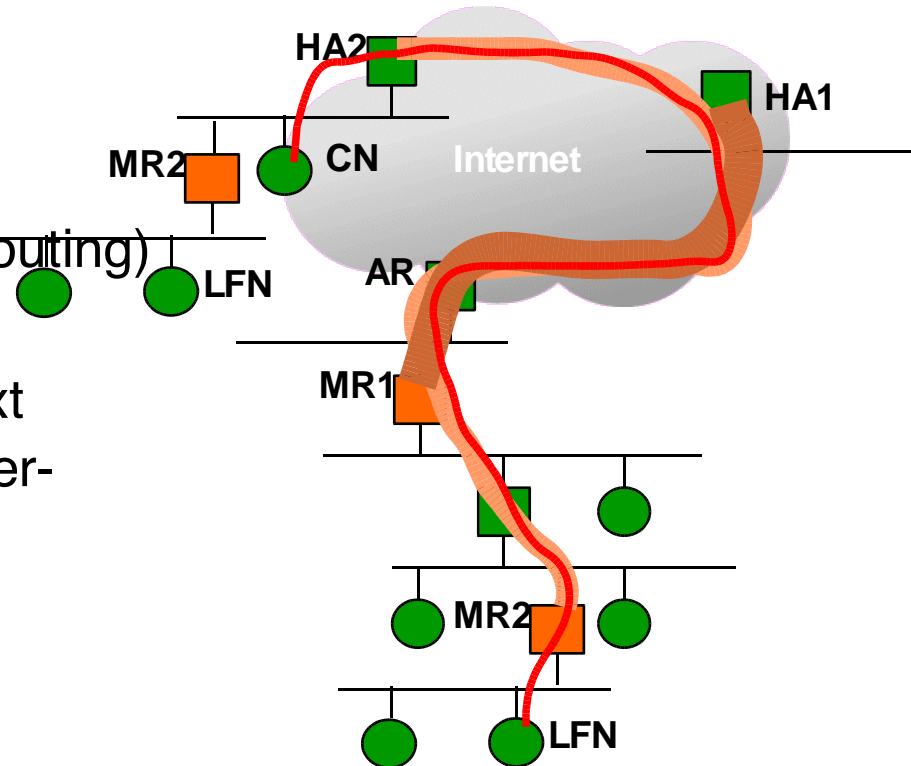

- ◆ Many personal propositions have been submitted
 - ◆ “a la Mobile IPv6” type
 - ◆ They usually do not address the same issues, or all of them
 - ◆ Tradeoffs:
 - ◆ **Which entity to modify (MR, CN, MNN, intermediate router)**
- ◆ The WG is chartered to produce a problem statement document (analysis of the solution space)
 - ◆ draft-thubert-nemo-ro-taxonomy deals with some of the RO issues, but not all
- ◆ The WG will decide what to do next based on the results of the analysis – it may possibly be re-chartered, or closing down.
 - ◆ May be good to at least do some kind of optimization, like:
 - ◆ **Reducing overhead of the nested tunnels**
 - ◆ **Adapting Mobile IPv6 for VMNs**
 - ◆ **Avoiding routing within the infrastructure when both peers are in the same NEMO**

Mobility Problem

- ◆ # types
 - ◆ Access Networks in public transportation
 - ◆ Networks of sensors in vehicles
 - ◆ Personal Area Networks
- ◆ # usages
 - ◆ Transportation / Health-care / Army /
- ◆ # configurations
 - ◆ Single mobile IP-subnet
 - ◆ **MNN may be fixed (LFNs), or mobile (VMNs, LMNs)**
 - ◆ Multiple mobile IP-subnet
 - ◆ **May be a static configuration: in a vehicle**
 - ◆ **May be mobile on from another: multiple cars forming a train**
 - ◆ **May be nested: hierarchy of NEMO**
 - ◆ Multihomed
 - ◆ **Multiple interfaces, multiple MRs**
 - ◆ Nested and Multihomed

Mobility Problem

- ◆ # mobility patterns
 - ◆ Local-mobility: e.g. Trains vs Global-mobility: e.g. Private cars
 - ◆ High mobility frequency vs Moving seldomly
 - ◆ Predictive vs non Predictive
 - ◆ MANET of NEMO vs NEMO of MANET
- ◆ All of these types, usages, configurations, mobility patterns imply different cases where RO is needed:
 - ◆ RO between a MNN and CN in the infrastructure
 - ◆ RO between MNNs in distinct NEMOs
 - ◆ RO between MNNs within the same NEMO
 - ◆ For each of the above,
 - ◆ **The NEMO is possibly nested**
 - ◆ **MNNs and CNs may be fixed or mobile**
 - ◆ Potentially complex problem to solve

- ◆ Potential Categories of Approaches
 - ◆ Two-tier addressing :
 - ◆ **Mobile IPv6-like, HMIPv6, Correspondent Router**
 - ◆ Separation between identifier and locator: e.g. LIN6
 - ◆ Multicast
 - ◆ Overlay Network: e.g. ORC
 - ◆ Routing-Based: using conventional or ad-hoc routing protocols
 - ◆ Renumbering: changing address/prefix
 - ◆ Combined
 - ◆ **e.g.1 Routing for local mobility (within the AS) and Two-tier for global mobility (between ASs)**
- ◆ A specific approach may be more suitable for the type of RO
 - ◆ e.g.: Ad-hoc routing protocols in nested NEMO solely made of individual mobile IP-subnet
 - ◆ Elected solution will probably be a combination of some of the above

RO a la MIP6: Routing Optimization Issues

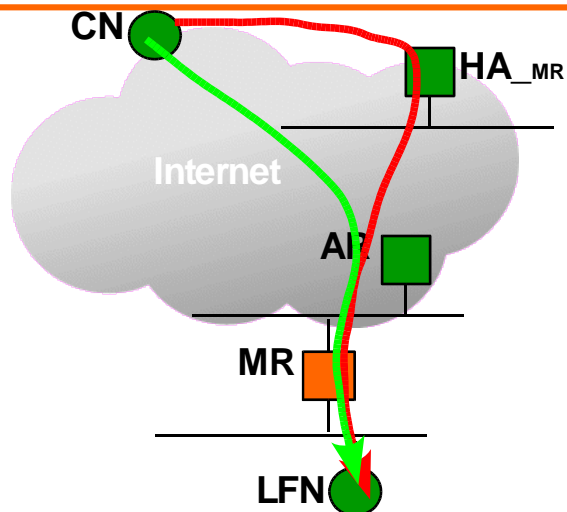

From CN to Local Fixed Node

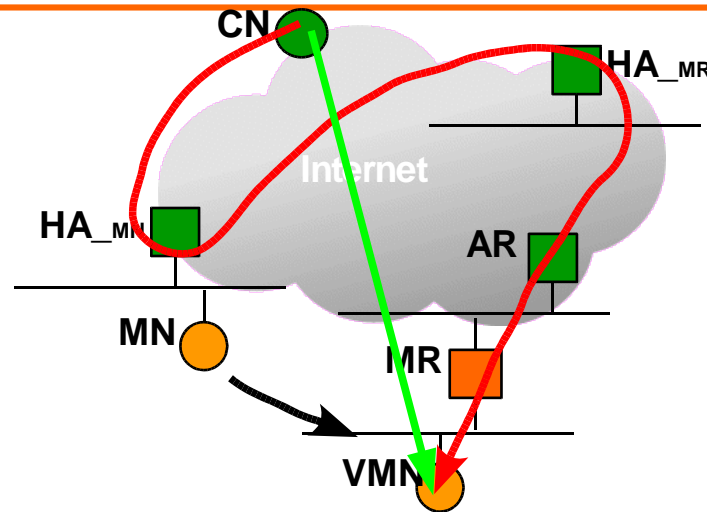

From CN to Visiting Mobile Node

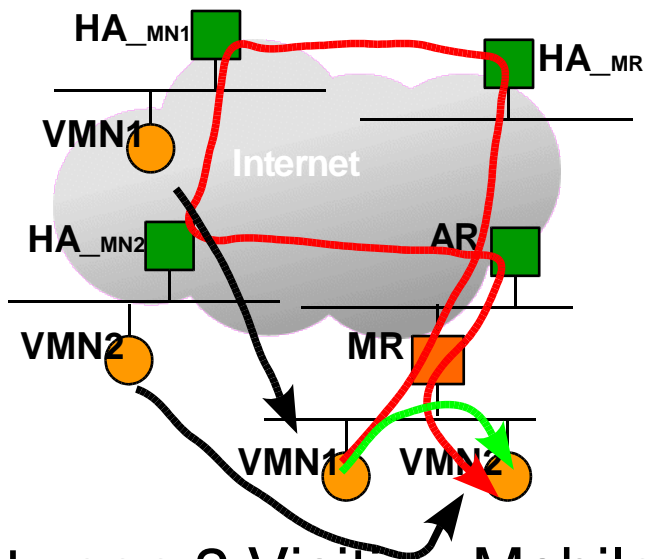

Between 2 Visiting Mobile Nodes

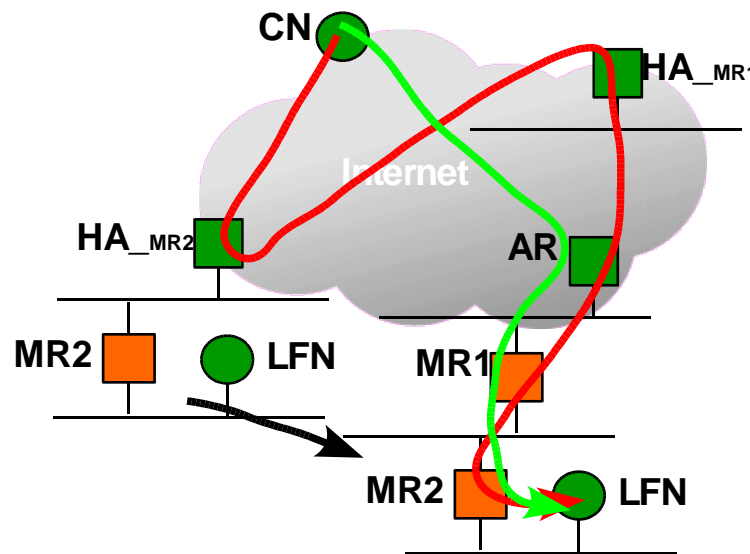

From CN to LFN in nested NEMO

RO a la MIP6: RO between MR/VMN and CN

- ◆ MR performs RO on behalf of MNNs
- ◆ Pros:
 - ◆ HA is bypassed
 - ◆ Transparent to MNNs
 - ◆ **No mobility support needed, can be plain IPv6 hosts**
 - ◆ MR, CN, HA are the only entities involved
- ◆ Cons:
 - ◆ BU explosion:
 - ◆ **not scalable for large number of CNs**
 - ◆ MIPv6 RR (Reverse Routability) test between MR and CN is broken
 - ◆ **because MNNs not reachable AT MR's CoA, but VIA MR's CoA**
 - ◆ Changed needed at the CN

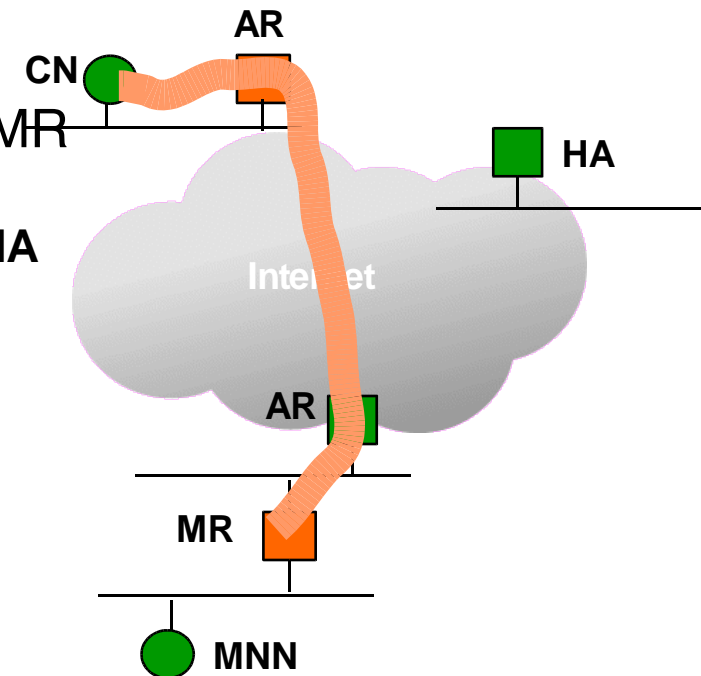

RO a la MIP6: RO from Visiting Mobile Node

- ◆ VMN / LMN participates in NEMO RO
- ◆ Pros:
 - ◆ HA is bypassed for VMNs / LMNs
 - ◆ May further reduce the number of tunnels required
- ◆ Cons:
 - ◆ No RO for LFNs
 - ◆ Impact the operations of VMH, MR, and HA

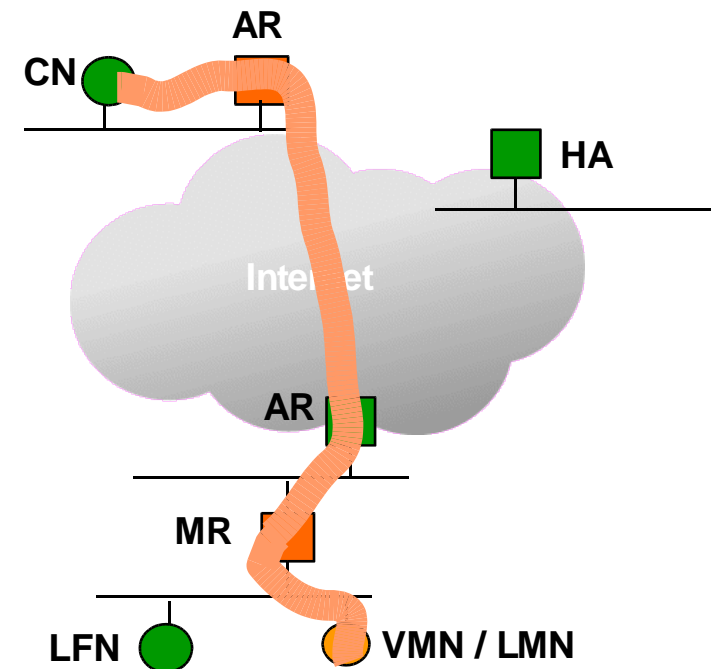

RO a la MIP6: RO with routing infrastructure

- ◆ Routing is optimized between CR (Correspondent Router) and MR/VMN
 - ◆ Add routes in specific routers
- ◆ Pros
 - ◆ CN can be a plain IPv6 host i.e. No mobility support function at all
- ◆ Cons:
 - ◆ May impact the operations of VMN, MR and HA
- ◆ Refs:
 - ◆ ORC [Wakikawa], CR [Thubert]

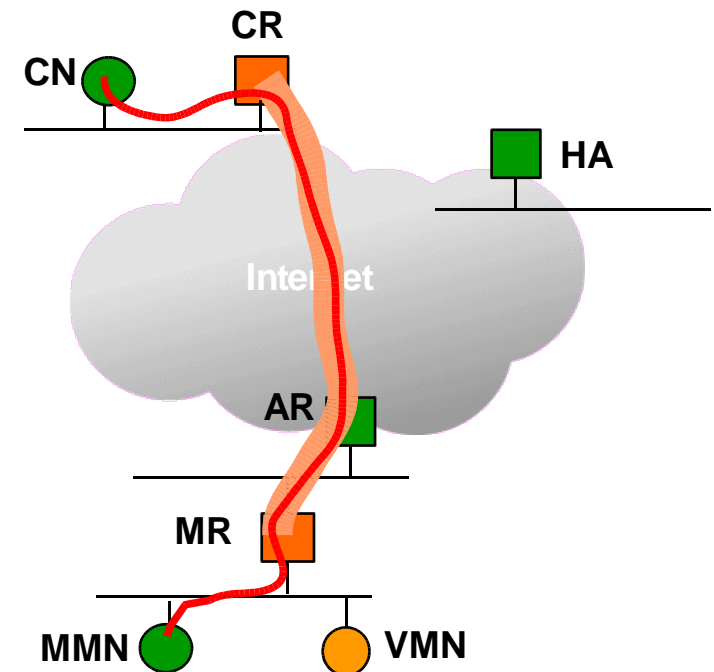

RO a la MIP6: RO for nested mobile network

- ◆ Root-MR maintains a tunnel to each HA
- ◆ Pros:
 - ◆ Reduce the number of tunnels
 - ◆ Should impact only operations of MR and HA
- ◆ Cons
 - ◆ Packets still experience 'dog-leg' routing

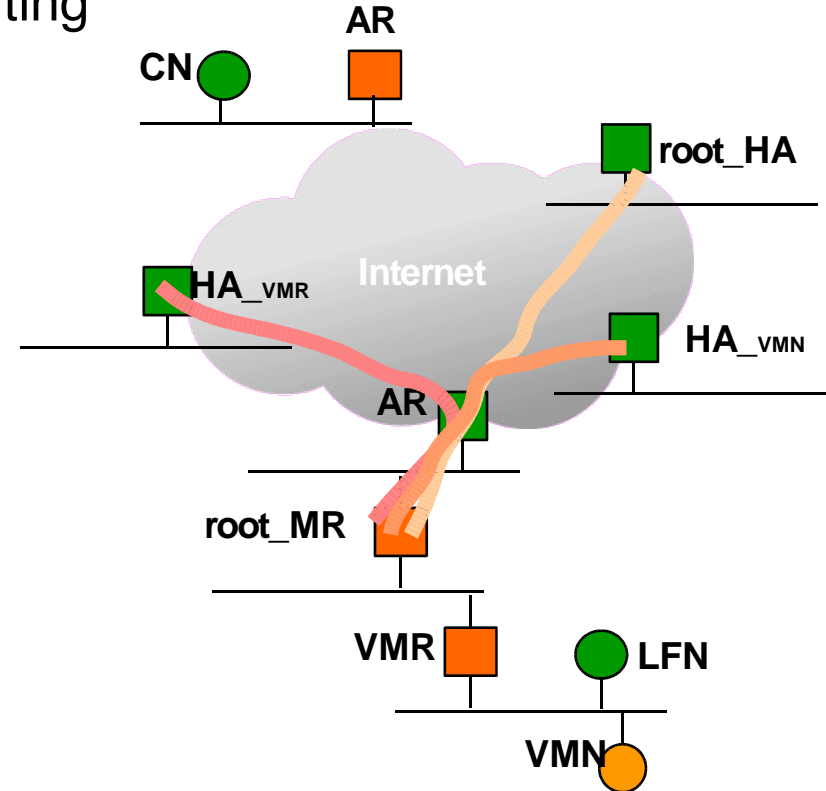

Conclusion

- ◆ NEMO is a very interesting and challenging research area
 - ◆ Multiple types, configuration, usages, applications
 - ◆ Complex configurations introduce potentially complex routing optimization issues
- ◆ IETF NEMO WG workload is well advancing
 - ◆ Basic Support: Session Maintenance, no RO
 - ◆ Extended Support: No decision made concerning RO
- ◆ There is much more to study than the “RO a la MIP6” approach and that won't be done in the NEMO WG
- ◆ In any case, network mobility is an opportunity to re-launch the mobility research activity (Routing Research Group or elsewhere)
 - ◆ Mobility support mechanisms
 - ◆ RO for mobility support

Questions ?

Thierry Ernst

ernst@sfc.wide.ad.jp

<http://www.sfc.wide.ad.jp/~ernst/>

<http://www.nautilus6.org>

IETF NEMO WG: <http://www.ietf.org/html.charters/nemo-charter.html>

NEMO Additional IETF page: <http://www.mobilenetworks.org/nemo>

Nautilus6 (NEMO-related activity): <http://www.nautilus6.org>

Book: 20000 Leagues Under the Sea (Jules Verne)

